

1. A fuel cell is basically
 - (A) An electro–mechanical energy conversion device
 - (B) An electro–chemical energy conversion device
 - (C) An electro–static energy conversion device
 - (D) A thermo–electric energy conversion device
 - (E) Answer not known

2. A fuel cell in order to produce electricity, burns
 - (A) Chromium
 - (B) Helium
 - (C) Hydrogen
 - (D) Nitrogen
 - (E) Answer not known

3. Supercapacitors are suitable for _____ applications.
 - (A) High power density
 - (B) Low power density
 - (C) Back up power
 - (D) High energy density
 - (E) Answer not known

4. Fuel cell performance is not limited by
 - (A) 1st Law of Thermo Dynamics
 - (B) 2nd Law of Thermo Dynamics
 - (C) 3rd Law of Thermo Dynamics
 - (D) 4th Law of Thermo Dynamics
 - (E) Answer not known

5. Consider a 12 V battery with a charge capacity of 150 Ah. Find the amount of current given by battery if it is discharged in 5 hours.
- (A) 36 A (B) 30 A
 (C) 180 A (D) 18.75 A
 (E) Answer not known
6. Choose the right one. The efficiency range of fuel cells (SOFC) of size 5 KW – 3 MW, is
- (A) 33% – 37% (B) 45% – 65%
 (C) 34% – 36% (D) 40% – 50%
 (E) Answer not known
7. The ideal or maximum theoretical efficiency (also called power coefficient) of a wind turbine can be defined as the ratio of
- (A) $\frac{\text{Power o/p from wind machine}}{\text{Power available in wind}}$
 (B) $\frac{\text{Power available in wind}}{\text{Power o/p from wind machine}}$
 (C) $\frac{\text{Speed of the Rotor tip}}{\text{Free wind speed}}$
 (D) $\frac{\text{Free wind speed}}{\text{Speed of the Rotor tip}}$
 (E) Answer not known

8. Local winds are caused by
- (i) Differential heating of land and water bodies
 - (ii) Differential heating of plains and mountains
- Choose the correct answer
- (A) Both (i) and (ii) are correct
 - (B) (i) only correct
 - (C) (ii) only correct
 - (D) Both (i) and (ii) are not correct
 - (E) Answer not known
9. In remote areas of Jammu and Kashmir and border districts of Arunachal Pradesh which one of the power plants are the only source of energy
- (A) PV – Diesel
 - (B) Micro hydel – PV
 - (C) Biomass – Diesel
 - (D) Solar – Biomass
 - (E) Answer not known
10. In a wind turbine the radius of the rotor is 3 metre has 24 blades, each 0.35 m wide, the solidity is
- (A) 54.6%
 - (B) 34.6%
 - (C) 64.6%
 - (D) 44.6%
 - (E) Answer not known

11. Wind speed is 10 m/s at the standard atmospheric pressure and air density is $1.226 \text{ J/kg} - \text{k/m}^3$. Find the total power density in wind stream
- (A) 800 w/m^2 (B) 700 w/m^2
(C) 613 w/m^2 (D) 713 w/m^2
(E) Answer not known
12. The maximum value of power coefficient in a wind turbine is
- (A) 0.693 (B) 0.593
(C) 0.493 (D) 0.395
(E) Answer not known
13. The wind power in wind mill is directly proportional to
- (A) Wind velocity (B) Cube of wind velocity
(C) Square of area (D) Square of wind velocity
(E) Answer not known
14. A solar cell (0.9 cm^2) receives solar radiation with photons of 1.8 eV energy having an intensity of 0.9 mw/cm^2 . Measurement show open – circuit voltage of 0.6 V/cm^2 , short circuit current of 10 mA/cm^2 , and the maximum current is 50% of the short circuit current. The efficiency of the cell is 25%.
- Calculate the fill factor
- (A) 1.124 (B) 0.0375
(C) 2.578 (D) 3.421
(E) Answer not known

15. Solar energy reaching per sq.m of earth atmosphere is
- (A) 0.36 KW (B) 1.36 KW
 (C) 2.36 KW (D) 3.36 KW
 (E) Answer not known
16. How much electrical energy does a 1.5 KW solar panel, working at full capacity produce in 5 hours?
- (A) 1.5 KWH (B) 7.5 KWH
 (C) 5 KWH (D) 75 KWH
 (E) Answer not known
17. The total energy that can be stored in a capacitor is given by
- V = Volume of dielectric
 ϵ = Constant
 E = Electric field strength
- (A) $V\epsilon E^2$ (B) $\frac{1}{2} V\epsilon E^2$
 (C) $\frac{1}{2} V^2\epsilon E$ (D) $V^2\epsilon E$
 (E) Answer not known
18. Angle made by plane surface with horizontal is called
- (A) Slope (B) Altitude angle
 (C) Zenith angle (D) Hour angle
 (E) Answer not known

19. The three main regions of solar spectrum is
- (A) Ultraviolet, visible and infrared
 - (B) Ultraviolet, spectral and gamma
 - (C) Visible, spectral and X ray
 - (D) Infrared, spectral and microwave
 - (E) Answer not known
20. An instrument which measures global or diffuse radiation on a horizontal surface is called
- (A) Pyranometer
 - (B) Pyrhelimeter
 - (C) Sunshine recorder
 - (D) Solar radiator
 - (E) Answer not known
21. A three phase squirrel cage induction motor is developing torque of 1500 sync. watts at 50 Hz and 1440 rpm (synchronous speed is 1500 rpm). If the motor frequency is now increased to 75 Hz using constant power mode, determine the new value of torque developed by motor at constant slip
- (A) 750 sync. watts
 - (B) 900 sync. watts
 - (C) 1000 sync. watts
 - (D) 1150 sync. watts
 - (E) Answer not known
22. A 3ϕ , 400 V, 50 Hz, 6 pole, star connected round rotor synchronous motor speed is lowered by keeping V/f constant and maintaining unity power factor. For the motor operation at 600 rpm the supply voltage will be
- (A) 240 V
 - (B) 400 V
 - (C) 230 V
 - (D) 800 V
 - (E) Answer not known

23. A separately excited dc motor is fed from a 500 V dc source through a one quadrant chopper. $R_a = 0.1\Omega$ and armature current is 200 A. The voltage and torque constant are 1.4 V/A – rad/sec and 1.4 N–M/A². The field current is 2 A. The duty cycle of chopper is 0.5. Find the speed of the motor.
- (A) 770.20 rpm (B) 774.62 rpm
 (C) 756.83 rpm (D) 784.38 rpm
 (E) Answer not known
24. In V/f speed control, at low speed the maximum torque capability of the motor
- (A) Reduces due to stator resistance drop
 (B) Remains constant
 (C) Increases
 (D) Becomes zero
 (E) Answer not known
25. The generated energy is supplied to the source then it is called as
- (A) Dynamic braking (B) Regenerative braking
 (C) Reverse current braking (D) Resistive braking
 (E) Answer not known
26. A boost converter with a 20 KHz switching frequency is operating with a 50% duty cycle. The connected load is 7Ω . Determine the value of critical inductance so that current i_L is continuous
- (A) $21.9\mu F$ (B) $19.5\mu F$
 (C) $15.7\mu F$ (D) $24.8\mu F$
 (E) Answer not known

27. RMS voltage equation of multiple pulse width modulator invertors is,

(A) $V_s \left(\frac{d}{\pi} \right)^{\frac{1}{2}}$ (B) $V_s \left(\frac{\pi}{d} \right)^{\frac{1}{2}}$

(C) $V_s \left(\frac{\pi}{2d} \right)^{\frac{1}{2}}$ (D) $V_s \left(\frac{2d}{\pi} \right)^{\frac{1}{2}}$

(E) Answer not known

28. In a PWM inverter, f_0 and f are the frequencies in Hz for the carrier signal and reference signal respectively. Then the number of pulse per half cycle is

(A) $N = \frac{f}{f_0}$ (B) $N = \frac{f}{2f_0}$

(C) $N = \frac{f_0}{2f}$ (D) $N = \frac{f_0}{f}$

(E) Answer not known

29. The most efficient method of controlling the output voltage of the inverter circuit is

(A) Pulse – width modulation control

(B) Series inverter control

(C) External control of AC output voltage

(D) External control of DC input voltage

(E) Answer not known

30. A step up chopper is operated with constant duty cycle D . If V_o is the DC output voltage and V_s is input voltage then the ratio $\frac{V_o}{V_s}$ will be
- (A) $1 - D$ (B) D
 (C) $\frac{D}{1 - D}$ (D) $\frac{1}{1 - D}$
 (E) Answer not known
31. 1ϕ , 220 V, 1 KW heater is connected to half wave controlled rectifier and is fed from a 220 V, 50 Hz ac supply. When the firing angle $\alpha = 90^\circ$, the power absorbed by the heater will be nearly
- (A) 1000 W (B) 750 W
 (C) 500 W (D) 250 W
 (E) Answer not known
32. The value of a voltage ripple factor of a single phase full wave mid point rectifier is
- (A) 1.211 (B) 0.482
 (C) 0.8106 (D) 0.672
 (E) Answer not known
33. A single phase half wave ac voltage controller feeds a load of $R = 20\Omega$ with an input voltage of 230 V, 50 Hz. Firing angle of thyristor is 45° . Determine RMS value of output voltage
- (A) 224.682 V (B) 232 V
 (C) 220.32 V (D) 192 V
 (E) Answer not known

34. The ratio of RMS value of output voltage to the DC value of output voltage in a AC to DC converters is called as
- (A) Ripple factor (B) Rectifier efficiency
 (C) Form factor (D) Utilization factor
 (E) Answer not known
35. The single phase full converter bridge with RLE load behaves like a line commutated inverter. When the firing angle delay α is
- (A) $\alpha > 180^\circ$ (B) $\alpha > 90^\circ$
 (C) $\alpha < 90^\circ$ (D) $\alpha = 90^\circ$
 (E) Answer not known
36. A MOSFET rated for 12 A carries a periodic current as shown in figure on state resistance is 0.2Ω . The average on state loss is

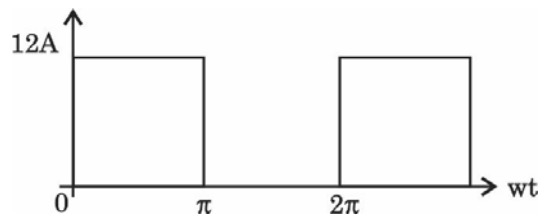

- (A) 14.4 W
 (B) 28.4 W
 (C) 30 W
 (D) 3 W
 (E) Answer not known

37. In figure PIV required for the diode is

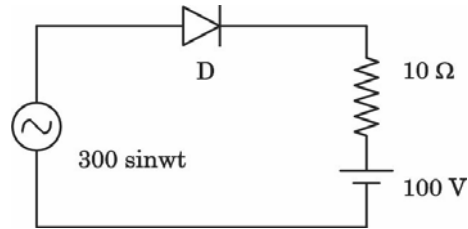

- (A) 300 V (B) 100 V
(C) 200 V (D) 400 V
(E) Answer not known

38. Choose the correct statement

- (A) MOSFET is a uncontrolled device
(B) MOSFET is a voltage controlled device
(C) MOSFET is a current controlled device
(D) MOSFET is a temperature controlled device
(E) Answer not known

39. The main advantage of IGBT over SCR in power electronics is

- (A) Reduced weight
(B) Self commutating capability
(C) Very high reliability
(D) Self cooling property
(E) Answer not known

40. The insulated gate bipolar transistor's (IGBT)'s structure is a
- (A) P–N–P structure connected by a MOS gate
 - (B) N–P–N structure connected by a MOS gate
 - (C) P–N–P–N structure connected by a MOS gate
 - (D) N–P–N–P structure connected by a MOS gate
 - (E) Answer not known
41. The purpose of Meter Service Provider (MSP) is _____ is the electricity deregulation.
- (A) To install the energy meters at the consumer premises
 - (B) To maintain the energy meters at the consumer premises
 - (C) To install and maintain energy meters at the consumer premises
 - (D) To collect the energy meter data
 - (E) Answer not known
42. The energy quality index can be defined as the ratio of _____
- (A) Energy Loss / Energy input
 - (B) $\frac{\text{Energy availability of output}}{\text{Energy availability of input}}$
 - (C) $\frac{\text{Energy availability of Input}}{\text{Energy availability of output}}$
 - (D) Energy input / Energy output
 - (E) Answer not known

43. The steady state stability limit of a synchronous generator can be increased by
- (A) Increasing its reactance
 - (B) Increasing its moment of inertia
 - (C) Increasing its excitation
 - (D) Decreasing its reactance
 - (E) Answer not known
44. Consider the following statements :
- A differential relay is used for a 3–phase transformer protection to avoid maloperation due to
- (1) Saturation of current transformer
 - (2) Mismatching of the current ratio for current transformers
 - (3) Difference in connections on both sides of power transformer
 - (4) Current setting multipliers
- Of these statement
- (A) (1) and (4) are correct
 - (B) (1) and (2) are correct
 - (C) (1), (2) and (3) are correct
 - (D) (2), (3) and (4) are correct
 - (E) Answer not known
45. It is possible to design a station so that the faults that develop are mostly earth – faults.
- (A) Differential protection
 - (B) Distance protection
 - (C) Fault bus protection
 - (D) Over current protection
 - (E) Answer not known

46. An impedance relay is a
- (A) Voltage restrained over current relay
 - (B) Voltage restrained directional relay
 - (C) Current restrained directional relay
 - (D) Current restrained over-voltage relay
 - (E) Answer not known
47. The impedance per phase of 3 phase transmission line on a base of 100 MVA, 100 KV is 2 PU. The value of this impedance on a base of 400 MVA and 400 KV would be
- (A) 1.5 P.U.
 - (B) 1.0 P.U.
 - (C) 0.5 P.U.
 - (D) 0.25 P.U.
 - (E) Answer not known
48. The zero sequence current of a generator for line to ground fault is $j 2.4$ P.U. Then the current through the neutral during the fault is
- (A) $j 2.4$ P.U.
 - (B) $j 0.8$ P.U.
 - (C) $j 7.2$ P.U.
 - (D) $j 0.24$ P.U.
 - (E) Answer not known
49. Gauss – Seidel interactive method can be used for solving a set of
- (A) Linear differential equations only
 - (B) Linear algebraic equations only
 - (C) Both linear and nonlinear algebraic equations
 - (D) Both linear and nonlinear differential equations
 - (E) Answer not known

50. A balanced three phase load is supplied from a 3ϕ supply. The contact in line c of the triple pole switch contactor fails to connect when switched on. If the line currents in lines a and b records 25 A each, then the positive sequence component of the current is

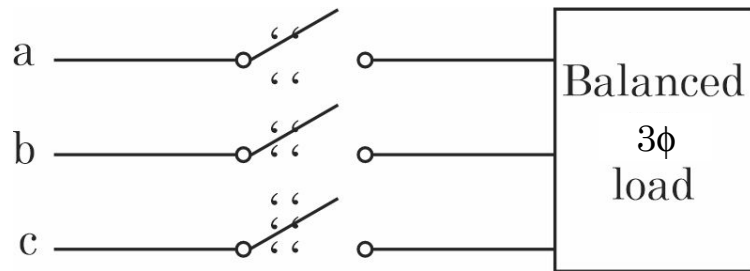

- (A) $14.4 \angle 30^\circ \text{ A}$ (B) $25.0 \angle -30^\circ \text{ A}$
 (C) $14.4 \angle -30^\circ \text{ A}$ (D) $25.0 \angle 30^\circ \text{ A}$
 (E) Answer not known
51. The bus admittance matrix of the network shown in the figure. For which the marked parameters are per unit impedance is

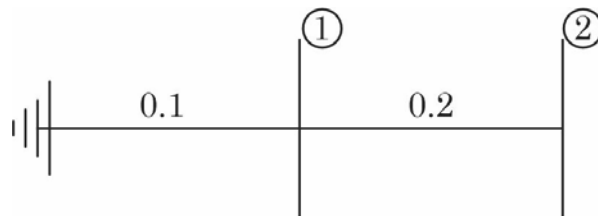

- (A) $\begin{bmatrix} 0.3 & -0.2 \\ -0.2 & 0.2 \end{bmatrix}^{-1}$ (B) $\begin{bmatrix} 0.3 & 0.2 \\ 0.2 & 0.2 \end{bmatrix}$
 (C) $\begin{bmatrix} 0.3 & -0.2 \\ -0.2 & 0.2 \end{bmatrix}$ (D) $\begin{bmatrix} 15 & -5 \\ -5 & 5 \end{bmatrix}$
 (E) Answer not known

52. The surge impedance of a 3 phase 400 KV transmission line is 400Ω . The surge impedance loading is
- (A) 400 MW (B) 100 MW
(C) 1600 MW (D) 200 MW
(E) Answer not known
53. The breakdown strength of air at a barometric pressure of 760 mm and temperature of 25°C is
- (A) 19 KV/cm (max) (B) 30.4 KV/cm (max)
(C) 33 KV/cm (max) (D) 30 KV/cm (max)
(E) Answer not known
54. When bundle of conductors are used in place of single conductors, the effective inductance and capacitance will respectively
- (A) Increase and decrease
(B) Decrease and increase
(C) Decrease and remain unaffected
(D) Increase and remain unaffected
(E) Answer not known
55. HVDC transmission lines are more economical for
- (A) Short distance transmission
(B) Long distance transmission
(C) Any distance transmission
(D) Interconnected system
(E) Answer not known

59. Economizer in thermal power plant is used to heat
- (A) Air
 - (B) Feed water
 - (C) Steam
 - (D) Fuel
 - (E) Answer not known
60. A generating station has maximum demand of 10,000 KW and the daily load on the station is as follows
- 11 PM to 6 AM – 2000 KW
 - 6 AM to 8 AM – 3500 KW
 - 8 AM to 12 Noon – 8000 KW
 - 12 Noon to 1 PM – 3000 KW
 - 1 PM to 5 PM – 7500 KW
 - 5 PM to 7 PM – 8500 KW
 - 7 PM to 9 PM – 10000 KW
 - 9 PM to 11 PM – 4500 KW
- Find the load factor
- (A) 48%
 - (B) 50%
 - (C) 55%
 - (D) 58%
 - (E) Answer not known

61. The value of a matrix in $\dot{X} = A X$ for the system described by the differential equation $\ddot{Y} + 2\dot{Y} + 3Y = 0$ is

(A) $\begin{bmatrix} 1 & 0 \\ -2 & -1 \end{bmatrix}$

(B) $\begin{bmatrix} 1 & 0 \\ -1 & -2 \end{bmatrix}$

(C) $\begin{bmatrix} 0 & 1 \\ -2 & -1 \end{bmatrix}$

(D) $\begin{bmatrix} 0 & 1 \\ -3 & -2 \end{bmatrix}$

(E) Answer not known

62. The transfer function of a PI controller is

(A) $K_p + K_i S$

(B) $K_p + \frac{K_i}{S}$

(C) $\frac{K_p}{S} + K_i S$

(D) $K_p S + \frac{K_i}{S}$

(E) Answer not known

63. The characteristic equation for a third order system is $S^3 + 2S^2 + 4S + K = 0$ for the system to be stable, what should be the value of gain K ?

(A) $0 < K < 8$

(B) $0 < K < 4$

(C) $2 < K < 8$

(D) $0 < K < 2$

(E) Answer not known

64. The necessary condition for a system to be stable

I : All the coefficients of characteristic equation should present

II : All the coefficients of the characteristic equation should be positive

Choose the correct answer

(A) Statement I and II are true

(B) Statement I is true but II is false

(C) Statement I is false but II is true

(D) Statement I and II are false

(E) Answer not known

65. The steady state error resulting from input $r(t) = 2 + 3t + 4t^2$ for given system is

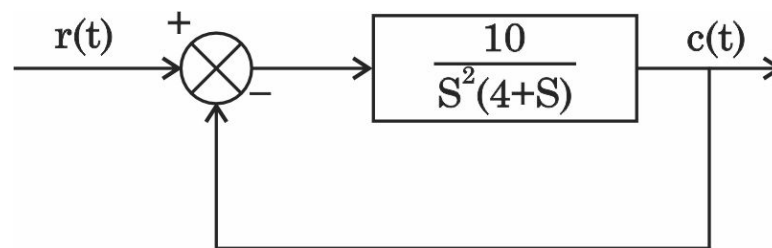

(A) 2.4

(B) 4.0

(C) Zero

(D) 3.2

(E) Answer not known

66. The characteristic equation of a control system is given below

$F(S) = S^4 + S^3 + 3S^2 + 2S + 5 = 0$. The system is

(A) Stable

(B) Critically stable

(C) Conditionally stable

(D) Unstable

(E) Answer not known

67. Choose the right matches :

1. For stable system phase margin – Positive
 2. For critical stability gain margin – Zero
 3. For oscillatory system phase margin – Negative
 4. For instability gain margin – Positive
- (A) 1 and 2 are correct (B) 1 and 3 are correct
(C) 2 and 3 are correct (D) 3 and 4 are correct
(E) Answer not known

68. The closed loop transfer function of a system is

$$\frac{C(S)}{R(S)} = \frac{K}{S^2 + AS + K}$$

The characteristic equation of the system is

- (A) $S^2 + AS + 2K = 0$ (B) $S^2 + AS + K = 0$
(C) $S^2 + AS + K^2 = 0$ (D) $S^2 + AS = 0$
(E) Answer not known

69. Steady state error is

- (A) $e_{ss} = \lim_{s \rightarrow 0} SE(s)$
(B) $e_{ss} = \lim_{s \rightarrow \infty} SE(s)$
(C) $e_{ss} = \lim_{s \rightarrow 0} E(s)$
(D) $e_{ss} = \lim_{s \rightarrow \infty} E(s)$
(E) Answer not known

70. Construct routh array and determine the stability of the system whose characteristics equation is $S^6 + 2S^5 + 8S^4 + 12S^3 + 20S^2 + 16S + 16 = 0$, also determine the number of roots lying on right half of s -plane, left half of s plane and on imaginary axis
- (A) Marginally stable (B) Unstable
 (C) Stable (D) Zero
 (E) Answer not known

71. The network as shown in the figure is a

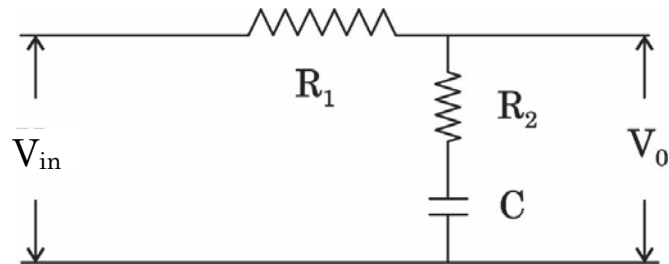

- (A) Phase lag network (B) Phase lead network
 (C) Differentiator (D) Phase lead lag network
 (E) Answer not known
72. The characteristic equation of a control system is $S^3 + KS^2 + 9S + 18 = 0$. When the system is marginally stable, the frequency of sustained oscillations is
- (A) 2 rad/sec (B) 1.414 rad/sec
 (C) 1.732 rad/sec (D) 3 rad/sec
 (E) Answer not known

73. The transfer function $\frac{V_2(s)}{V_1(s)}$ of the circuit shown below is

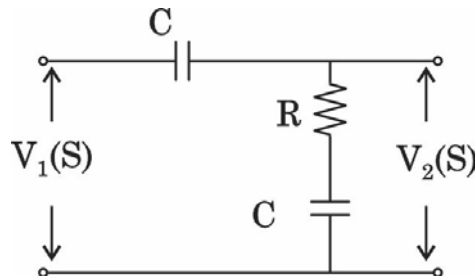

- (A) $\frac{2 + RCS}{RCS}$ (B) $\frac{1 + RCS}{2 + RCS}$
- (C) $\frac{1 + RCS}{RCS}$ (D) $\frac{2 + RCS}{1 + RCS}$
- (E) Answer not known
74. In a block diagram representation
- (A) Output is the product of input and transfer function where all of them are in laplace domain
- (B) Output is the ratio of input and transfer function where all of them are in laplace domain
- (C) Output is the product of input and transfer function where all of them are in time domain
- (D) Output is the ratio of input and transfer function where all of them are in time domain
- (E) Answer not known
75. In a pneumatic system _____ is the analogous quantity to electric current in a electrical system.
- (A) Air flow rate (B) Pressure
- (C) Temperature (D) Volume
- (E) Answer not known

76. The impulse response of a linear system is $e^{-t}, t > 0$. The corresponding transfer function is

- (A) $\frac{1}{S(S+1)}$ (B) $\frac{1}{S+1}$
(C) $\frac{1}{S}$ (D) $\frac{S}{S+1}$
(E) Answer not known

77. For second order system, if both the roots of the characteristic equation are real, then the damping ratio will be

- (A) Less than unity (B) Equal to unity
(C) Equal to zero (D) Greater than unity
(E) Answer not known

78. In the general transfer function, of a second-order system expressed as

$$\frac{C(S)}{R(S)} = \frac{\omega_n^2}{S^2 + 2\zeta\omega_n S + \omega_n^2}$$

The terms ζ and ω_n stands respectively for

- (A) Error coefficient and undamped natural frequency of oscillations
(B) Damping factor and undamped natural frequency of oscillations
(C) Phase margin and undamped natural frequency of oscillations
(D) Damping factor and angular velocity
(E) Answer not known

79. The value of C/R ratio of the following signal flow graph is

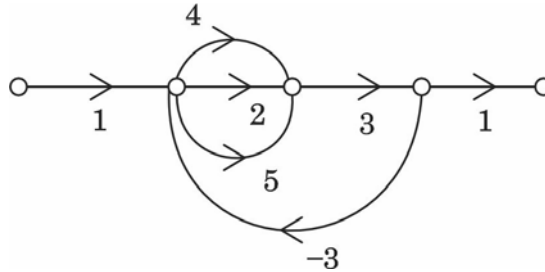

- (A) $\frac{33}{83}$ (B) $\frac{33}{100}$
 (C) $\frac{36}{83}$ (D) $\frac{36}{100}$
 (E) Answer not known

80. Maximum overshoot formula is

- (A) $\frac{C(t_p) - C(\alpha)}{C(\alpha)} \times 100$ (B) $\frac{C(\alpha) - C(t_p)}{C(t_p)} \times 100$
 (C) $\frac{C(t_p) - C(\alpha)}{C(t_p)} \times 100$ (D) $\frac{C(\alpha) - C(t_p)}{C(\alpha)} \times 100$
 (E) Answer not known

81. When a load is connected to $230 \angle 10^\circ V$, it draw a current of $10 \angle -50^\circ A$, what is the real and reactive power of the load?

- (A) 1992 W, 1150 VAR (B) 1150 W, 1150 VAR
 (C) 1626 W, 2086 VAR (D) 1150 W, 1992 VAR
 (E) Answer not known

82. A three phase balanced inductive load draw a current of 10 A and consumed 6 KW when connected to 400 V supply. What is the power factor of the load?
- (A) 0.866 lag (B) 0.5 lag
(C) 0.866 lead (D) 0.5 lead
(E) Answer not known
83. The reading of the wattmeter connected to measure the reactive power in a 3ϕ circuit is given by zero, the line voltage is 400 V and line current 15 A; then the power factor of the circuit is
- (A) Zero (B) Unity
(C) 0.8 (D) 0.5
(E) Answer not known
84. A balanced star – connected load of $(4 + j3)\Omega$ per phase is connected to a balanced 3 – phase 400 V supply. The phase current is 12 A. The value of real power is
- (A) 5650.24 watts (B) 6650.88 watts
(C) 7650.78 watts (D) 8750.67 watts
(E) Answer not known

85. For the network shown in the figure if $V_s = 1V$ and $V = 0$, then $I = -5A$ and if $V_s = 0$ and $V = 1V$, then $I = \frac{1}{2}A$. The values of I_{SC} and R_N of the Norton's equivalent across AB would be respectively

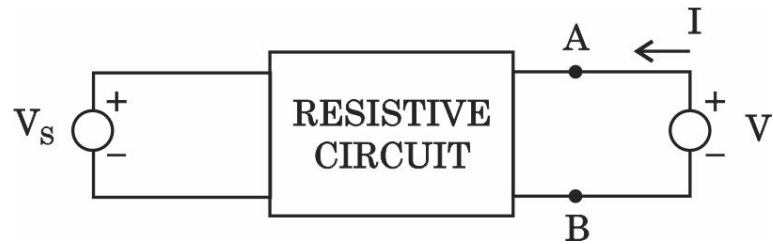

- (A) $-5A$ and 2Ω (B) $10A$ and 0.5Ω
 (C) $5A$ and 2Ω (D) 2.5Ω and 5Ω
 (E) Answer not known
86. The ϕ parameters of the circuit shown below are

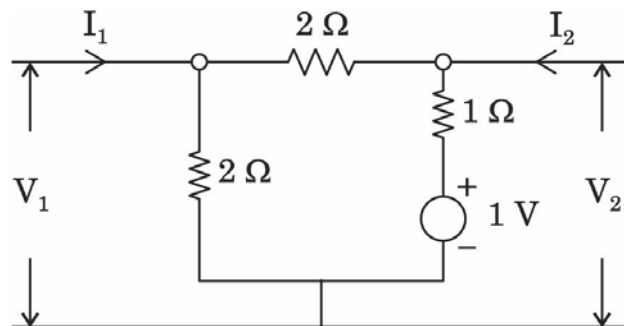

- (A) $1, \frac{-1}{2}, \frac{-1}{2}$ and $\frac{3}{2}$ (B) $2, -2, -2$ and 1
 (C) $1, -1, -1$ and 3 (D) $2, -1, -1$ and 3
 (E) Answer not known

87. The expression for current i in $1\text{ k}\Omega$ resistor in the circuit below when the switch is moved from x to y is

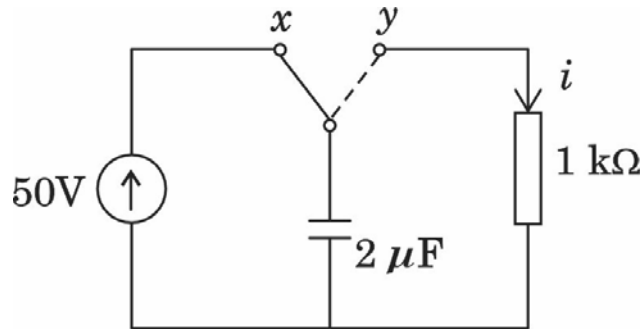

- (A) $0.05 e^{-500t} \text{ A}$ (B) $5 e^{-500t} \text{ A}$
 (C) $0.5 e^{-1000t} \text{ A}$ (D) $50 e^{-1000t} \text{ A}$
 (E) Answer not known
88. In an a.c. circuit, $V = 100 \sin(\omega t + 30^\circ) \text{ V}$, $i = 5 \sin(\omega t - 30^\circ) \text{ A}$. Find apparent power and reactive power
- (A) 500 VA, 433 VAR (B) 354 VA, 306.5 VAR
 (C) 250 VA, 217 VAR (D) 354 VA, 177 VAR
 (E) Answer not known
89. The parameters widely used in transmission line theory
- (A) Z – Parameters
 (B) Y – Parameters
 (C) ABCD – Parameters
 (D) H – Parameters
 (E) Answer not known

90. A RL series circuit draws a current of 1 A, when connected across 10 V, 1 rad/sec a.c supply. Assuming the resistance to be $5\ \Omega$, find the inductance of the circuit

- (A) $\sqrt{75}H$ (B) $100\ mH$
 (C) $\sqrt{10}\ mH$ (D) $0.1H$
 (E) Answer not known

91. For the circuit shown in fig. determine the bandwidth. The resonant frequency of the circuit is 7.12 Hz.

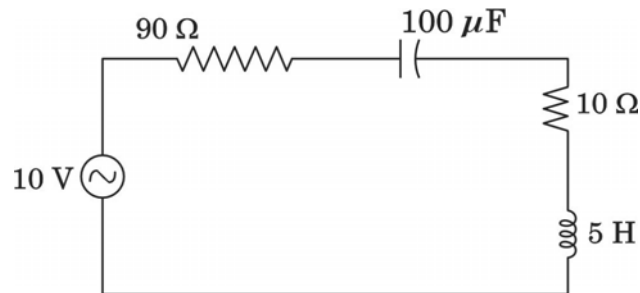

- (A) 2.17 Hz (B) 3.23 Hz
 (C) 2.57 Hz (D) 3.178 Hz
 (E) Answer not known

92. The peak factor and form factor of the sinusoidal waveform are _____ respectively.

- (A) 1.11, 1.414 (B) 1.414, 1.11
 (C) 1.41, 1.14 (D) 1.14, 1.11
 (E) Answer not known

93. What is the phase angle between voltage and current of a series RLC circuit at resonance?
- (A) 0 (B) 45
(C) 60 (D) 90
(E) Answer not known
94. If the lower cut-off frequency is 2400 Hz and the upper cut-off frequency is 2800 Hz, then the bandwidth will be
- (A) 2400 Hz (B) 5200 Hz
(C) 400 Hz (D) 2800 Hz
(E) Answer not known
95. Determine the RMS current in the circuit shown in fig

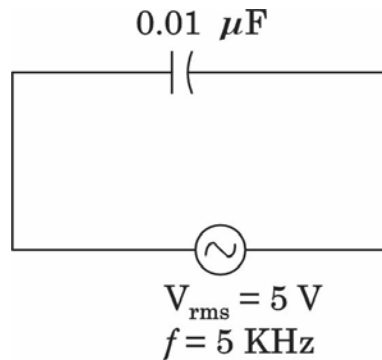

- (A) 1.57 mA (B) 2.57 mA
(C) 3.57 mA (D) 0.57 mA
(E) Answer not known

96. Determine the thevenin voltage V_{TH} across 'AB' for the circuit shown in fig

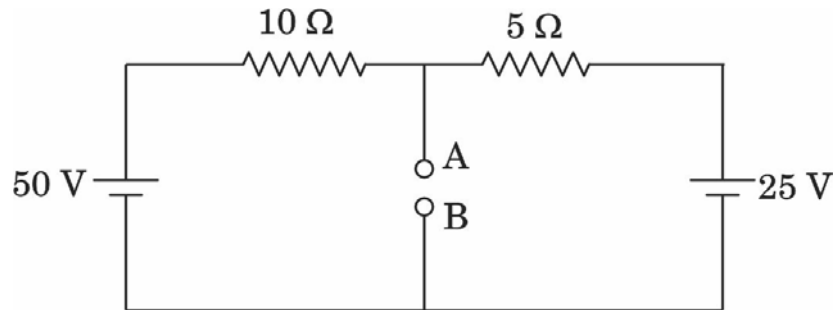

- (A) 33.3 V
 (B) 23.3 V
 (C) 13.3 V
 (D) 3.3 V
 (E) Answer not known
97. Find the current i in the following circuit diagram

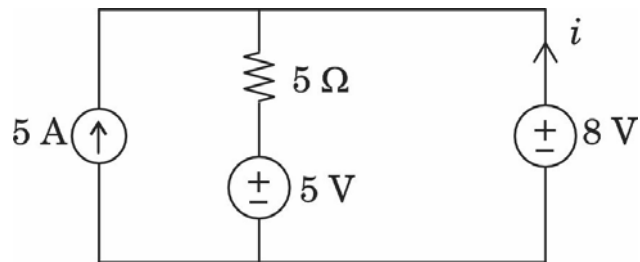

- (A) 2.2 A
 (B) 4.4 A
 (C) -2.2 A
 (D) -4.4 A
 (E) Answer not known
98. The resistance of a 5 m length of wire is $600\ \Omega$. Determine the resistance of an 8 m length of the same wire.
- (A) $1000\ \Omega$
 (B) $980\ \Omega$
 (C) $960\ \Omega$
 (D) $1200\ \Omega$
 (E) Answer not known

99. An inductance of 2 mH takes a current of $i = 5.0(1 - e^{-5000t})A$. The stored energy and voltage across inductor are
- (A) 25 mJ, $25e^{-5000t}(V)$ (B) 50 mJ, $50e^{-5000t}(V)$
 (C) 25 mJ, $50e^{-5000t}(V)$ (D) 50 mJ, $25e^{-5000t}(V)$
 (E) Answer not known
100. Superposition theorem is valid for _____ response.
- (A) Only power (B) Only current
 (C) Only voltage (D) Voltage and current
 (E) Answer not known
101. Ampere's law point form is given by
- (A) $\text{Curl } (V) = I$ (B) $\text{Curl } (B) = I$
 (C) $\text{Curl } (D) = J$ (D) $\text{Curl } (H) = J$
 (E) Answer not known
102. A coil of 200 turns is wound on a non-magnetic core having a mean circumference of 100 mm and a cross sectional area of 100 mm². The inductance of the coil corresponding to a magnetising current of 2A will be
- (A) 5.024 μH (B) 50.24 μH
 (C) 16.42 μH (D) 1.642 μH
 (E) Answer not known

103. Biot-Savart's Law states the relation between magnetic field intensity and
- (A) Electric Intensity (B) Electric Current
 (C) Work Done (D) Vector Potential
 (E) Answer not known
104. $C = 40 \text{ nF}$, $d = 0.1 \text{ mm}$ and $A = 0.15 \text{ m}^2$. Determine the relative permittivity of the dielectric material used in a parallel plate capacitor
- (A) 2.56 (B) 2.82
 (C) 3.01 (D) 3.46
 (E) Answer not known
105. The laws of electro magnetic induction (Faraday's and Lenz's Law) are summarized in the following equation
- (A) $e = L \frac{di}{dt}$ (B) $e = -\frac{d\psi}{dt}$
 (C) $e = iR$ (D) $R = \frac{e}{i}$
 (E) Answer not known
106. A conductor of Length L has current I passing through it, when it is placed parallel to strong magnetic field. The force experienced by the conductor will be
- (A) BL^2I (B) BIL
 (C) BI^2L (D) Zero
 (E) Answer not known

107. In a lossless medium, the intrinsic impedance $\eta = 60\pi$ and $\mu_r = 1$. The value of the dielectric constant ϵ_r
- (A) 2 (B) 1
 (C) 4 (D) 8
 (E) Answer not known
108. The value of Standing Wave Ratio (SWR) in free space for transmission coefficient $\Gamma = -\frac{1}{3}$
- (A) $\frac{2}{3}$ (B) 0.5
 (C) 4.0 (D) 2.0
 (E) Answer not known
109. Plane $y = 0$ carries a uniform current of $30a_z$ mA/m. At $(1, 10, -2)$, the magnetic field intensity is
- (A) $-15ax$ mA/m (B) $15ax$ mA/m
 (C) $477.5a_y$ A/m (D) $18.95a_y$ nA/m
 (E) Answer not known
110. A point charge of $2nc$ is located at the origin. Find the value of potential at $p(1, 0, 0)$ m.
- (A) 06.42 V (B) 27.01 V
 (C) 17.98 V (D) 36.12 V
 (E) Answer not known

111. Point charges $Q_1 = 2nc$ and $Q_2 = 3nc$ are at a distance apart. Choose the incorrect statement
- (A) A point charge $Q_3 = -5nc$ located at the midpoint between Q_1 and Q_2 experience no net force
 - (B) The force on Q_1 is repulsive
 - (C) As the distance between them decreases the force on Q_1 increases linearly
 - (D) The force on Q_2 is the same in magnitude as that on Q_1
 - (E) Answer not known
112. For a perfect conductor, the field strength at a distance equal to the skin depth is X% of the field strength at its surface. The value of X% is
- (A) Zero
 - (B) 50%
 - (C) 36%
 - (D) 26%
 - (E) Answer not known
113. The work done by the force $F = 4a_x - 3a_y + 2a_z$ N in giving a $1nc$ charge a displacement of $10a_x + 2a_y - 7a_z$ m is
- (A) $103nJ$
 - (B) $60nJ$
 - (C) $64nJ$
 - (D) $20nJ$
 - (E) Answer not known

114. The electric flux density is defined as
- (A) Permittivity multiplied by electric field intensity
 - (B) Permittivity multiplied by number of magnetic flux lines
 - (C) Permeability multiplied by electric field intensity
 - (D) Permeability multiplied by number of flux lines
 - (E) Answer not known
115. If \bar{E} is the electric field intensity, $\nabla(\nabla \times \bar{E})$ is equal to
- (A) Zero
 - (B) \bar{E}
 - (C) $|\bar{E}|$
 - (D) Null Vector
 - (E) Answer not known
116. Usually a collection of positive charge is considered for constructing a Gaussian surface. If a Gaussian surface encloses a collection of negative charges, then for such a surface
- (A) A normal component of D will become zero
 - (B) The normal component of D will point inwards
 - (C) The normal component of D will point outwards
 - (D) The normal component of D will point infinity
 - (E) Answer not known
117. Find the total charge enclosed by a cube of 2 m side, centered at the origin with the edges parallel to the axes when \bar{D} over the cube is $5x^3 \bar{a}_x \text{ C/m}^3$
- (A) 10 C
 - (B) 20 C
 - (C) 30 C
 - (D) 40 C
 - (E) Answer not known

118. Determine the divergence of the vector $x^2 yz a_x + xz a_z$
- (A) 0 (B) 1
 (C) $2xyz + x$ (D) $2xyz + y$
 (E) Answer not known
119. In a non magnetic medium the peak value of electric field is given as 12 V/M. If the relative permittivity is given as $\epsilon_r = 100/\pi^2$. The time average power per m² will be
- (A) $6\pi^2 W$ (B) $0.6/\pi W$
 (C) $6/\pi^2 W$ (D) $12/\pi^2 W$
 (E) Answer not known
120. Gauss law relates the electric field intensity E with volume charge density ρ at point as
- (A) $\nabla \times E = \epsilon_0 \rho$ (B) $\nabla \cdot E = \frac{\rho}{\epsilon_0}$
 (C) $\nabla \times E = \frac{\rho}{\epsilon_0}$ (D) $\nabla \cdot E = \epsilon_0 \rho$
 (E) Answer not known
121. The resolution of an 8 bit DAC will be
- (A) $\frac{1}{288}$ (B) $\frac{1}{128}$
 (C) $\frac{1}{255}$ (D) $\frac{1}{64}$
 (E) Answer not known

122. A 10-bit digital ramp ADC is using 300 KHz clock. The maximum time is
- (A) $3576 \mu s$ (B) $3776 \mu s$
(C) $3476 \mu s$ (D) $3376 \mu s$
(E) Answer not known
123. What waveform is applied to the horizontal plates in order to display a sine wave in a CRO?
- (A) Sinusoidal (B) Square
(C) Sawtooth (D) Triangular
(E) Answer not known
124. X – Y recorders
- (A) Record one quantity with respect to another quantity
(B) Record one quantity on X-AXIS with respect to time on Y-AXIS
(C) Record one quantity on Y-AXIS with respect to time on X-AXIS
(D) Record one quantity on X-AXIS with respect to time on Z-AXIS
(E) Answer not known

125. The following statements are about thermocouple transducer :

- I. A thermocouple is an active transducer
- II. The electrical energy generated by temperature gradient

Choose the correct answer :

- (A) Statements I and II are true
- (B) Statements I and II are false
- (C) Statements I is true but II is false
- (D) Statements I is false but II is true
- (E) Answer not known

126. A quartz crystal has a thickness of 2 mm and a voltage sensitivity of $0.1 \frac{V_m}{N}$. It is subjected to a pressure of 20 kN/m². The voltage developed will be

- (A) 1 V
- (B) 2 V
- (C) 4 V
- (D) 8 V
- (E) Answer not known

127. In a direct magnetic tape recording system, the reproducing lead and amplifier characteristics are

- (A) – 6 db/octave, + 6 db/octave
- (B) – 6 db/octave, + 20 db/decade
- (C) + 6 db/octave, – 6 db/octave
- (D) – 20 db/ decade, + 20 db/decade
- (E) Answer not known

128. Kelvin double bridge is best suited for the measurement of
- (A) Low capacitance value
 - (B) High value of capacitance
 - (C) Low value of resistance
 - (D) High value of resistance
 - (E) Answer not known

129. The following factors decide the accuracy in a bridge measurement :
- (1) Accuracy of the null indicator
 - (2) Accuracy of the bridge components
 - (3) Sensitivity of the null indicator
 - (4) Applied voltage to the bridge system

Select the correct answer using the code given :

- (A) (1) and (2)
- (B) (2) and (3)
- (C) (3) and (4)
- (D) (1) and (3)
- (E) Answer not known

130. The disadvantage of Maxwell's bridge is that

- (A) Both inductance and Q of a coil cannot be measured
- (B) Measurement is not independent of frequency
- (C) Inductance cannot be measured over wide range of Q
- (D) Number of components is large
- (E) Answer not known

131. In an Anderson Bridge, the unknown inductance is measured in term of known

- (A) Resistance
- (B) Capacitance
- (C) Inductance and Resistance
- (D) Resistance and Capacitance
- (E) Answer not known

132. LVDT has

- (A) One Primary Coil and One Secondary Coil
- (B) One Primary Coil and Two Secondary Coils
- (C) Two Primary Coils and One Secondary Coil
- (D) Two Primary Coils and Two Secondary Coils
- (E) Answer not known

133. The nominal ratio of the current transformer is

- (A) Rated Secondary Current / Rated Primary Current
- (B) Rated Primary Current / Rated Secondary Current
- (C) Rated Primary Voltage / Rated Primary Current
- (D) Rated Primary Current / Rated Secondary Voltage
- (E) Answer not known

134. Which one of the following passive components has the most precise and accurate standard?

- (A) Resistance
- (B) Inductance
- (C) Capacitance
- (D) Conductance
- (E) Answer not known

135. A 100 V, voltmeter has full scale accuracy of 5% when reading 50 V, the error will be

- (A) 10%
- (B) 5%
- (C) 2.5%
- (D) 1.25%
- (E) Answer not known

136. The primary winding of a 1000/5 A, 50 Hz current transformer has a single turn. Its secondary burden consists of non-inductive impedance of 1.4Ω . The ratio error is
- (A) -3.85% (B) -4%
(C) $+3.85\%$ (D) $+4\%$
(E) Answer not known
137. A wattmeter has a full scale range of 2500 W. It has an error $\pm 1\%$ of true value. The range of reading if true power is 1250 W?
- (A) 1225 W – 1275 W (B) 1245 W – 1255 W
(C) 1200 W – 1300 W (D) 1237.5 W – 1262.5 W
(E) Answer not known
138. In an electro-dynamometer type wattmeter,
- (A) the current coil is made fixed
(B) the pressure coil is fixed
(C) any one of the two coils can be made fixed
(D) both the coils should be movable
(E) Answer not known
139. A 5A ammeter has a resistance of 0.01Ω . Determine the efficiency of the instrument
- (A) 0.05 A per watts (B) 20 A per watts
(C) 0.002 A per watts (D) 500 A per watts
(E) Answer not known

140. The operating coil of A 250 V moving iron voltmeter has a resistance of $500\ \Omega$ and an inductance of 1 H. The series resistance is $2000\ \Omega$. The instruments reads correctly when a direct voltage of 250 V is applied. What will it read when 250 V at 50 Hz is applied?
- (A) 300 V (B) 248 V
(C) 358 V (D) 200 V
(E) Answer not known
141. A stepper motor with a step angle of 15° has a stepping frequency of 300 steps/second. The stepper motor speed will be
- (A) 300 rpm (B) 750 rpm
(C) 720 rpm (D) 350 rpm
(E) Answer not known
142. The amount of torque required to move a stepper motor one full step is called
- (A) holding torque (B) residual torque
(C) detent torque (D) developed torque
(E) Answer not known
143. A 3ϕ , 11 kV, 50 Hz, 10 MVA star connected synchronous generator has armature reactance of $2.2\ \Omega/\text{phase}$. The leakage reactance is 0.15 times the armature reactance. The armature resistance is negligible. The synchronous reactance per phase is
- (A) $2.35\ \Omega$ (B) $2.05\ \Omega$
(C) $2.53\ \Omega$ (D) $0.33\ \Omega$
(E) Answer not known

144. In the 'V' curve shown in figure for a synchronous motor, the parameter of y and x co-ordinates are respectively

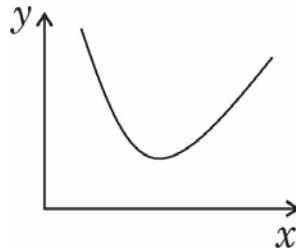

- (A) armature current and field current
- (B) power factor and field current
- (C) armature current and torque
- (D) torque and field current
- (E) Answer not known

145. Damper winding in a synchronous motor

- (A) Reduces winding losses
- (B) Serves to start the motor
- (C) Improves p.f of the motor
- (D) Increases hunting of the motor
- (E) Answer not known

146. A 4 pole 50 Hz synchronous machine runs at

- (A) 750 rpm.
- (B) 1500 rpm.
- (C) 3000 rpm.
- (D) 1440 rpm.
- (E) Answer not known

147. A rotor of a hysteresis synchronous motor
- (A) Has salient poles
 - (B) Has low permeability
 - (C) Slip behind the stator flux
 - (D) Is made of high-retentivity hard steel
 - (E) Answer not known
148. A 25 kVA, $Y - \Delta$ connected, 3 phase transformer has voltage rating of 3.3 kV on primary side. If the turns ratio is 5:1, then the line current on secondary side is
- (A) 37.88 AA
 - (B) 65.6 A
 - (C) 50 A
 - (D) 13.12 A
 - (E) Answer not known
149. The supply voltage to an induction motor is reduced by 10%. By what percentage, approximately, will the maximum torque decrease?
- (A) 5%
 - (B) 10%
 - (C) 20%
 - (D) 40%
 - (E) Answer not known

150. Match the List I and List II and select correct answer :

List I (Machine)		List II (Graph)	
(a) D.C Motor		1. Circle diagram	
(b) D.C Generator		2. V-curve	
(c) Alternator		3. Open circuit characteristics	
(d) Induction motor		4. Speed-torque characteristics	

- | | (a) | (b) | (c) | (d) |
|-----|------------------|-----|-----|-----|
| (A) | 4 | 3 | 1 | 2 |
| (B) | 3 | 4 | 2 | 1 |
| (C) | 4 | 3 | 2 | 1 |
| (D) | 3 | 4 | 1 | 2 |
| (E) | Answer not known | | | |

151. A 2000/200 V, 20 KVA ideal transformer has 66 turns in the secondary. The number of primary turns is

- | | |
|----------------------|---------|
| (A) 440 | (B) 660 |
| (C) 550 | (D) 330 |
| (E) Answer not known | |

152. The maximum efficiency of a 100 KVA transformer having iron loss of 900 W and Full load copper loss of 1600 W occurs at _____ KVA.

- | | |
|----------------------|------------|
| (A) 60 KVA | (B) 75 KVA |
| (C) 80 KVA | (D) 90 KVA |
| (E) Answer not known | |

153. In Practice, Plugging or Reverse Current Braking is used in
- (A) controlling elevators, rolling mills, printing presses and machine tools
 - (B) quick motor reversal desired
 - (C) load has overhauling characteristics
 - (D) sudden stopping of motor
 - (E) Answer not known
154. The armature torque of a DC motor is a function of its
- (A) Pole flux and Speed
 - (B) Armature current and pole flux
 - (C) Speed and armature current
 - (D) Speed alone
 - (E) Answer not known
155. In a DC Machine, the current in each armature coil of lap connected armature is equal to
- (A) 1.5 times the terminal armature current
 - (B) 0.5 times the terminal armature current
 - (C) terminal armature current divided by number of poles
 - (D) number of poles divided by the terminal armature current
 - (E) Answer not known

156. The exciting coils of the commutating poles are connected
- (A) In series with the armature
 - (B) In parallel with the armature
 - (C) In series with the field coil
 - (D) In parallel with the field coil
 - (E) Answer not known
157. The speed of a D.C motor is
- (A) Directly proportional to flux per pole
 - (B) Inversely proportional to flux per pole
 - (C) Inversely proportional to applied voltage
 - (D) Inversely proportional to armature current
 - (E) Answer not known
158. If the load current and flux of a dc motor are held constant and voltage applied across its armature is increased by 10%, its speed will
- (A) decrease by about 10%
 - (B) remain unchanged
 - (C) increase by about 10%
 - (D) increase by about 20%
 - (E) Answer not known

159. A 250 V, 4 pole, wave wound DC series motor has 782 conductors on its armature. Its armature and series field resistance is 0.75 ohm. The motor takes a current of 40 A. Estimate its speed and gross torque developed if it has a flux per pole of 25 mWb
- (A) 250 N–M (B) 251 NM
 (C) 248 NM (D) 249 NM
 (E) Answer not known
160. The induced emf in a dc machine when running at 500 rpm. is 180 V. What is the value of induced emf while the machine is running at 600 rpm by assuming flux to be constant
- (A) 230 V (B) 216 V
 (C) 242 V (D) 208 V
 (E) Answer not known
161. Characteristic equation of SR flipflop is
- (A) $S + R Q_n$ (B) $S + \bar{R} Q_n$
 (C) $\bar{S} + Q_n$ (D) $\bar{S} + \bar{R} Q_n$
 (E) Answer not known
162. Characteristic equation of T flipflop is
- (A) $T\bar{Q}_n + T$ (B) $Q_n T$
 (C) $T \cdot \bar{Q}_n + \bar{T} \cdot Q_n$ (D) $\bar{T} Q_n$
 (E) Answer not known

163. To simplify, $(A \cdot B + C \cdot D) \cdot [(\bar{A} + \bar{B})(\bar{C} + \bar{D})]$
- (A) AB (B) $A + B$
 (C) O (D) $\overline{A + B}$
 (E) Answer not known
164. The logic circuit has three inputs A , B and C whose output will be high only when a majority of the inputs are high. The simplified output expression will be
- (A) $BC + AC + AB$ (B) $\bar{B}\bar{C} + AC + \bar{A}B$
 (C) $\bar{B}\bar{C} + \bar{A}\bar{C} + AB$ (D) $AB + \bar{B}\bar{C} + BC$
 (E) Answer not known
165. The primary difference between counter and register is
- (A) A register counts data
 (B) A counter can store 'n' bit data but register can store one bit data
 (C) A register has no specific sequence of data
 (D) A counter has no specific sequence of data
 (E) Answer not known
166. A ripple counter with n flip flops can function as a
- (A) $n : 1$ counter (B) $\frac{n}{2} : 2$ counter
 (C) $2n : 1$ counter (D) $2^n : 1$ counter
 (E) Answer not known

167. The logic family which has minimum power dissipation is

- (A) TTL
- (B) I^2L
- (C) ECL
- (D) CMOS
- (E) Answer not known

168. The CMOS NAND gate is constructed using

- (A) NMOS transistors for pull up and PMOS transistors for pull down circuit
- (B) PMOS transistors for pull up and NMOS transistors for pull down circuit
- (C) PMOS transistors for both pull up and pull down circuit
- (D) NMOS transistors for both pull up and pull down circuit
- (E) Answer not known

169. A digital circuit shown in figure will act as

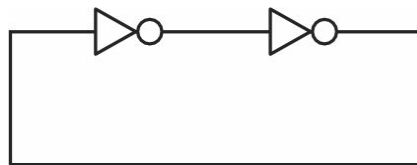

- (A) Oscillator
- (B) Bistable multivibrator
- (C) Mono stable multivibrator
- (D) An astable multivibrator
- (E) Answer not known

170. Universal gates are

- (A) NOR Gate
- (B) AND Gate
- (C) NAND Gate
- (D) NOR Gate and NAND Gate
- (E) Answer not known

171. An op-amp has a differential gain of 10^3 and a CMRR of 100. The output voltage of the op-amp with inputs of $120\ \mu V$ and $80\ \mu V$ will be
- (A) 26 mV (B) 41 mV
(C) 100 mV (D) 200 mV
(E) Answer not known
172. If an amplifier with open loop gain of 10^4 and feedback factor $\beta = 0.1$ has lower 3 dB frequency 100 Hz and upper 3 dB frequency as 1 KHz. Find the lower 3 dB frequency in the presence of feedback
- (A) 0.1 Hz (B) 100 Hz
(C) 10000 Hz (D) 1000 Hz
(E) Answer not known
173. In which amplifier the operating point is at an extreme end of its characteristic, so that the quiescent power is very small
- (A) Class A (B) Class B
(C) Class AB (D) Class C
(E) Answer not known

174. Which of the following is correct?

Negative feedback amplifiers increase

(i) Bandwidth

(ii) Distortion

(iii) Gain

(iv) Noise

(A) (i) and (iv) only

(B) (ii) only

(C) (ii) and (iii) only

(D) (i) only

(E) Answer not known

175. Feedback in amplifier always helps in

(A) Controlling its output

(B) Increasing its gain

(C) Reducing its input impedance

(D) Stabilizes its gain

(E) Answer not known

176. A single phase full-waverectifier use semiconductor diodes has transformer voltage is 35 V rms to center tap. The load consists of a $40 \mu F$ capacitor in parallel with a 250Ω resistor. The diode and transformer resistances and leakage reactance may be neglected. The power line frequency is 50 Hz. Calculate the dc current I_{dc} in the circuit

(A) 132 mA

(B) 100 mA

(C) 90 mA

(D) 250 mA

(E) Answer not known

177. In a zener regulator circuit, the ripple voltage $V_r(t)$ has a rms value of 2 V, find the rms value of the output ripple $V_{r_{out}}(t)$ for $R_S = 300 \Omega$, $r = 10 \Omega$ and $R_L = 3k \Omega$. Assume that the value of V_{dc} is such that the diode is biased in the breakdown region
- (A) 54.5 mV (B) 34.5 mV
(C) 64.5 mV (D) 74.5 mV
(E) Answer not known
178. Calculate I_C and I_E for a transistor that has $\alpha_{dc} = 0.98$ and $I_B = 100 \mu A$. Determine the value of β_{dc} (or h_{FE}) for the transistor
- (A) 36 (B) 49
(C) 56 (D) 72
(E) Answer not known
179. For which of the following rectifiers, the peak inverse voltage is $2V_m$, where V_m is the maximum value of the input voltage
- (A) Center-tapped full wave rectifier
(B) Bridge rectifier
(C) Half wave rectifier
(D) Half wave precision rectifier
(E) Answer not known

180. Improper biasing of a transistor circuit leads to
- (A) Excessive heat production in collector
 - (B) Distortion in output signal
 - (C) Faulty location of load line
 - (D) Heavy loading of emitter terminal
 - (E) Answer not known
181. Which layer is not present in the three-layer structure of IoT?
- (A) Application Layer
 - (B) Perception Layer
 - (C) Business Layer
 - (D) Network Layer
 - (E) Answer not known
182. In a PCM system, if the code word length is increased from 5 bits to 7 bits, the signal-to-quantization noise ratio improves by a factor of
- (A) $\frac{7}{5}$
 - (B) $\left(\frac{7}{5}\right)^2$
 - (C) 4
 - (D) 16
 - (E) Answer not known
183. The topology in which there are ' n ' devices and each device has $n - 1$ ports is
- (A) star topology
 - (B) bus topology
 - (C) ring topology
 - (D) mesh topology
 - (E) Answer not known

184. The serial data rate is known as the baud rate (ie)

- (A) No of bits of data transferred per second
- (B) No of bits of data transferred per min
- (C) No of bits of data transferred per hour
- (D) None of the above
- (E) Answer not known

185. The PCM for speech coding at standard rate of

- (A) 32 Kb/s
- (B) 64 Kb/s
- (C) 16 Kb/s
- (D) 8 Kb/s
- (E) Answer not known

186. Parseval's theorem $\sum_{n=0}^{N-1} |x(n)|^2 =$

- (A) $\frac{1}{N} \sum_{n=0}^{N-1} |x(K)|^2$
- (B) $\sum_{n=0}^{N-1} |x(K)|^2$
- (C) $\frac{1}{N} \sum_{n=0}^{N-1} |x(K)|$
- (D) $\sum_{n=0}^{N-1} \left| \frac{x(K)}{2} \right|$
- (E) Answer not known

187. A microcontroller normally has which of the following devices on-chip?

- (A) RAM
- (B) ROM
- (C) I/O
- (D) All the above
- (E) Answer not known

190. The 8279 is a
- (A) DMA controller
 - (B) Programmable keyboard display interface
 - (C) Counter
 - (D) Interrupt controller
 - (E) Answer not known
191. Bit set/reset mode in 8255 programmable peripheral interface is used to set or reset the pins of
- (A) Port A
 - (B) Port B
 - (C) Port C
 - (D) Port A and Port B
 - (E) Answer not known
192. In 8255, the control register is addressed by the pins A1 and A0 as
- (A) 00
 - (B) 01
 - (C) 10
 - (D) 11
 - (E) Answer not known
193. The simple input and output mode in 8255 is
- (A) Mode 0
 - (B) Mode 1
 - (C) Mode 2
 - (D) Mode 3
 - (E) Answer not known

194. Find the control word of the 8255 PPI for the following configuration all the ports of A, B and C are output ports, port A mode selection bits are 00, Port B mode selection bit is 0 and assume the simple input output mode of operation
- (A) 81 H (B) 80 H
(C) 25 H (D) 32 H
(E) Answer not known
195. If a microprocessor is capable of addressing 64K bytes of memory, its address bus width is
- (A) 16 BITS (B) 20 BITS
(C) 8 BITS (D) 12 BITS
(E) Answer not known
196. Which one of the following is not a vectored interrupt?
- (A) TRAP (B) INTR
(C) RST 3 (D) RST 7.5
(E) Answer not known

197. Find the value of register a after execution of the following instructions.

CLRC

MOV A, #26H

RRC A

RRC A

RRC A

(A) 84 H

(B) 09 H

(C) 86 H

(D) 13 H

(E) Answer not known

198. The status flag that exists in 8085 microprocessor but not in 8051 microcontroller is

(A) Carry flag

(B) Auxiliary flag

(C) Zero flag

(D) Overflow flag

(E) Answer not known

199. Do the two instructions mean the same?

1. BACK : DEC RO

JZ BACK

2. BACK : DJNZ RO, BACK

(A) Yes

(B) No

(C) Can't be Determined

(D) Yes And The Second One is preferred

(E) Answer not known

200. What is the maximum operating frequency of 8085 microprocessor?

- (A) 3 MHz
 - (B) 14 MHz
 - (C) 15 MHz
 - (D) 6 MHz
 - (E) Answer not known
-